

Installation and Operating Instructions

Model Number: RUM90XCOM

Description: 90cm Under-mount Rangehood



Contents

Congratulations!

Thank you for choosing one of our appliances. Before you use the appliance, we strongly recommend that you read through the whole user manual which provides important safety instructions and description of the product and the proper use of its functions.

To avoid the ever-present risks involved with using an electrical appliance it is vital that the oven is installed correctly and that you read the safety instructions carefully to avoid misuse and hazards. It is important that you retain these instructions and your proof of purchase along with any other important documents about this product for future reference.

Due to continual product development, Shriro reserves the right to alter specifications or appearances without notice.

Important Safety Instructions.....	1
Appliance Details	2
Installation Instructions.....	3
Operating Instructions.....	3
Light Replacement.....	3
Cleaning	4
Troubleshooting	4
Warranty Certificate.....	5

DISPOSAL INFORMATION

- Most of the packing materials are recyclable. Please dispose of these materials through your local recycling depot or by placing them in appropriate collection containers.
- If you wish to discard this product, please contact your local authorities and ask for the correct method of disposal.

Important Safety Instructions

IMPORTANT: Read the assembly instruction section and safety precautions of this booklet carefully before removing the contents of this carton.

1. In certain circumstances electrical appliances may be a safety hazard.
2. This appliance is not intended for use by persons (including children) with reduced physical, sensory or mental capabilities, or lack of experience or knowledge, unless they have been given supervision or instruction concerning the use of the appliance by a person responsible for their safety. Young children should be supervised to ensure that they do not play with the appliance.
3. Do not check the status of the filters whilst the cooker hood is operating.
4. Do not touch the light bulbs after use.
5. Do not disconnect the appliance with wet hands.
6. Do not disconnect the power supply by pulling on the cable.
7. Do not flambé underneath the range hood.
8. Avoid free flame, as it may cause damage to the filters and can be a fire hazard.
9. Unplug the appliance before carrying out maintenance, cleaning or replacing lamps.
10. If the power cord is damaged, it must be replaced by the manufacturer, an authorised service centre or similarly qualified persons to avoid a hazard.
11. For indoor use only.
12. It is recommended to operate the range hood prior to cooking.
13. It is recommended to leave the range hood in operation for 15 minutes after cooking is terminated in order to completely eliminate cooking vapours and odours.
14. Turn off the range hood when not in use.
15. Do not use the range hood if it is damaged, especially the supply cord and the case.
16. Do not immerse the range hood in liquid.
17. The exhaust air must not be discharged into a flue which is used for exhausting fumes from an appliance burning gas or other fuels (not applicable to appliances that only discharge the air back into the room).
18. Regulations concerning the discharge of air have to be fulfilled.
19. There shall be adequate ventilation of the room when the range hood is used at the same time as appliances burning gas or other fuels (not applicable to appliances that only discharge the air back into the room).
20. Clean the surface of the cooker hood regularly using a cloth moistened with denatured alcohol or a non-abrasive liquid detergent.
21. There is a fire risk if cleaning is not carried out in accordance with the instructions.
22. This unit is intended for use above hobs that are 900mm wide.
23. The range hood must be mounted at a minimum distance of 65cm above the cooking surface.
24. **CAUTION:** Accessible parts may become hot when used with cooking appliances.
25. Warning: Failure to install the screws or fixing device in accordance with these instructions may result in electrical hazards.

Appliance Details

Voltage:	220V-240V ~50Hz
Rated input power:	271W
Lamp Max:	2 x 3W GU10 LED

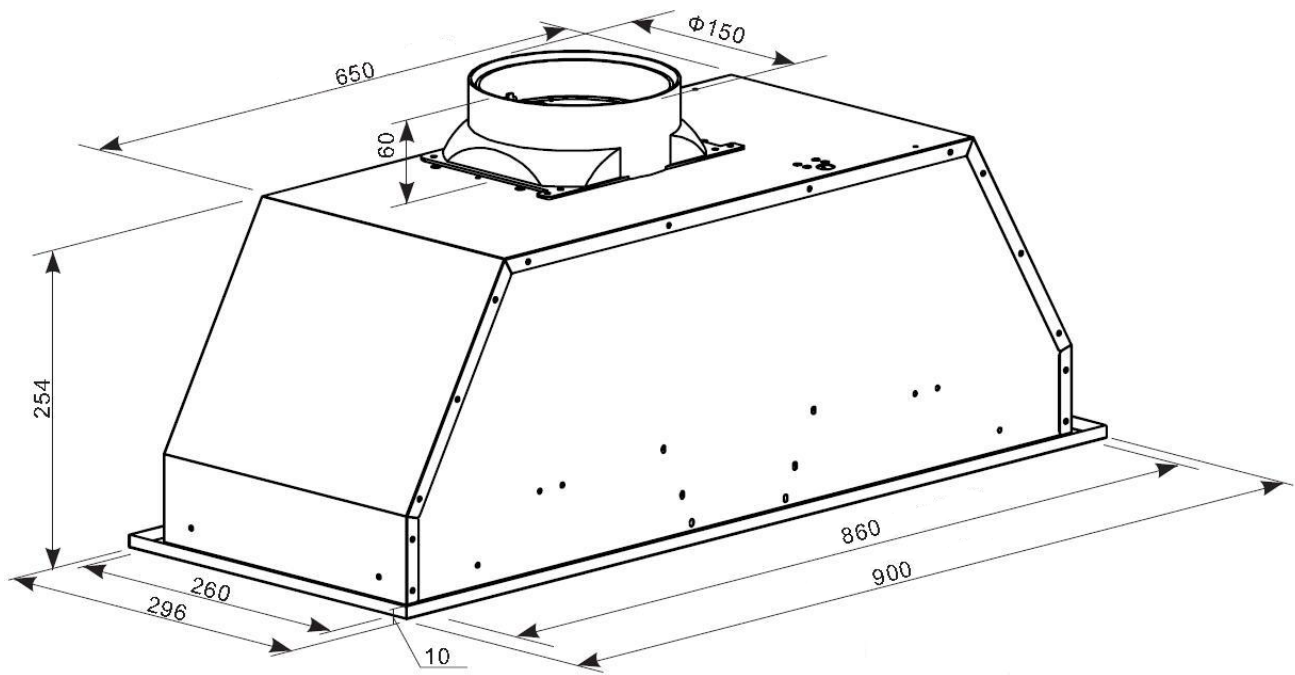

Installation Instructions

Please ensure that all power is switched off before installing the range hood. Installation must be in accordance to the local electrical authority and codes. This range hood must be earthed at all times for the operators' safety.

The G.P.O. for the range hood should be positioned to enable the user to turn the power off, to enable cleaning and any maintenance required.

Ensure that when installing the range hood, that it is protected from any possible damage from tools etc.

Ducting for this unit must be installed in accordance to the local authority. Ensure that the fixings used for this range hood are suitable.

Check the area where the range hood is to be fitted, to ensure that it is structurally sound.

Before using the appliance, remove the plastic coatings protecting the stainless steel finish.

Ensure that the wall is structurally sound, and is capable of carrying the weight of the range hood.

It is recommended that the dimension be checked on the range hood before installing.

1. The cooker hood should be placed at a distance of 650-750 mm from the cooking surface for the best effect.
2. Drill a hole in the cupboard, 865*265 mm for model RUM90XCOM.
3. Make sure the distance between the edge of the hole and the edge of the cupboard edge is at least 35mm. Take down the filter and remove the four screws on the panel.
4. Use random accessory tighten screws fix the hood into cabinet.
5. Use 4 screws fix the panel into body and equip the filter.
6. Install one-way valve: put the one-way valve into air outlet, Put on the one-way valve with air outlet.

Operating Instructions

Note: Before the unit can be operated, it must be ducted.

1. Connect the plug into the power.
2. Turn on wall socket power, this will start the Rangehood.

This Rangehood does not feature an On/Off switch, it is simply turned on and off from the power outlet at the wall. If your range hood does not function correctly when attempting any of the above, please ensure that your power is on and is functioning correctly. If the power seems to be functioning correctly in the house, there may be a problem with the range hood. Please call your authorised Omega service centre in this case to organise a service call.

Light Replacement

1. Switch the unit off and disconnect from mains power first.
2. Remove filter and read labels regarding maximum lamp ratings.
3. Press the light face and remove by turning in anti-clockwise direction.
4. Pull out the LED light bulb carefully and replace with the same type and same rated LED light bulb (240V 3W MAX).

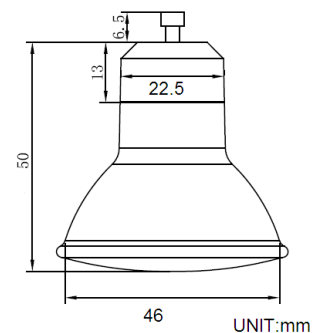

Cleaning

SAFETY PRECAUTION

Before cleaning your rangehood or performing any maintenance, please ensure that the rangehood is turned off at the power point.

Do not use abrasive cleaners to clean the rangehood. The use of warm soapy water and a cloth are recommended.

Ensure that the rangehood is cleaned regularly, as a build-up of grease and fat may occur otherwise.

The filters on the rangehood must be cleaned regularly to maintain efficiency, and prevent grease build up. The filter mesh is made of a high density Stainless Steel. It is recommended that this is undertaken every 4 – 6 weeks, depending on frequency of use. The filters can be cleaned with warm soapy water or a cloth.

Cleaning of the rangehood must be performed as described above; otherwise there is a possibility of a fire hazard due to grease and fat build up.

Troubleshooting

Fault	Possible Cause	Solution
Light on, but motor does not work	Fan switch turned off	Select a fan switch position.
	Fan switch failed	Contact Everdure Service.
	Motor failed	Contact Everdure Service.
Light does not work, motor does not work	House fuses blown	Reset/Replace fuses.
	Power cord loose or disconnected	Refit cord to power outlet. Switch power outlet on.
Oil leakage	One-way valve and the air ventilation entrance are not tightly sealed	Take down the one-way valve and seal with sealant.
	Leakage from the connection of U-shaped section and cover	Take U-shaped section down and seal.
Lights not working	Broken/Faulty LED lamp	Contact Everdure Service.
Insufficient suction	The distance between the rangehood and the gas top is too far	Refit the rangehood to the correct distance.
The Rangehood inclines	The fixing screw not tight enough	Tighten the hanging screw and make it horizontal.

Warranty Certificate

Terms and Conditions

If you are a consumer under the Australian Consumer Law, our goods come with guarantees that cannot be excluded under the Australian Consumer Law. You are entitled to a replacement or refund for a major failure and for compensation for any other reasonably foreseeable loss or damage. You are also entitled to have the goods repaired or replaced if the goods fail to be of acceptable quality and the failure does not amount to a major failure.

1. Shriro Australia Pty Limited ("Shriro") also warrants the following Shriro products against manufacturing defects and faulty materials, under normal use and subject to the exclusions in this certificate, for a period of:
 - Rangehood, Ovens, Cooktops, Dishwashers, Refrigeration - 24 months from date of original purchase for domestic use.
 - Uniduct – 12 months from date of original purchase for domestic use.
 - Ironing centre – 12 months from date of original purchase for domestic use.
 - Sinks sets– 5 years on stainless steel sink including draining bench from date of original purchase for domestic use, 6 months on all stainless steel accessories, including wire rack, colander and tray from date of original purchase for domestic use.
 - Laundry Tub - 5 years on stainless bowl, 24 months on Tap, Cabinet and other components from the date of original purchase for domestic use. "Original purchase", when used in this certificate, means purchase by the customer directly from Shriro or one of its approved suppliers.
2. This warranty is limited to the repair or replacement, at our option, within the warranty period of any component part which we at our discretion determine to contain faulty materials or a manufacturing defect in breach of this warranty. This warranty is subject to terms and conditions set out in this certificate.
3. The warranty only applies within Australia.
4. For warranty service outside of capital city metropolitan area or 30 km from nearest authorised service agent you will be liable for reasonable travelling expenses and the cost of transport of the product or parts to and from the service agent
5. To make a claim under this warranty, you must produce the original invoice or other purchase documentation as proof of the original purchase date. You must send your claim within 7 days of any alleged defect or failure of the product first becoming apparent. You are responsible for the expense of making a claim under this warranty.

This warranty is given by: Shriro Australia Pty Ltd ABN 28 002 386 129

Telephone: 1800 648 556

Facsimile: 1800 628 577

Email: customercare@shriro.com.au

www.robinhood.com.au

Attention: Customer Services Manager

Warranty exclusions

1. The warranty does not apply where, in Shriro's opinion:
 - The defect is caused by misuse, wear and tear, dirt, fire or accidental damage. The product has been repaired or serviced by an unauthorised person.
 - The product was not installed in accordance with our instructions.
 - The product was purchased overseas or was not designed for use in Australia.
 - The product was not used, cleaned or cared for in accordance with our instructions.
 - The product was used outdoors.
2. All Shriro Rangehoods are suitable for indoor use only and not suitable over BBQs or charcoal cookers designed for outdoor use.
3. In addition, this warranty does not extend to damage or defects which in our opinion, directly or indirectly arise from or are due to: exposing the product to acidic or corrosive materials or chemicals such as dyes, solvents, denture cleaner or acetone; using inappropriate household cleaning products such as abrasive cream or powder cleansers, furniture polish, bleach, mentholated spirits, drain cleaners, sugar soap, metal pads and strongly alkaline or acidic cleaners; heat damage, including from washing the product at high temperatures; impact or mishandling the product, including the impact caused by objects scraped along, thrown or dropped on the product surface or excessive weight being placed on the product; structural or support changes in or affecting the building or the application where the product has been installed; failure to clean or maintain the product as recommended; or any other causes specified in the product information as being excluded from this warranty.
4. Variations with the colour or gloss within the product or any ageing or fading of colour, shine or gloss level over time are not covered by this warranty. The warranty does not cover visual imperfections or blemishes in the surface and edges of the product that were not brought to your supplier's attention at the time you inspected the product.
5. We will not be responsible under this warranty for, nor pay the costs of, removing the existing product, or reinstalling the new product, or any associated costs or damages.
6. Charcoal filters and light bulbs are not covered by this warranty.

The benefits given by this warranty are in addition to other rights and remedies of consumers under any law in relation to the goods which cannot be excluded.

This warranty certificate is not intended to create a contract between Shriro Australia Pty Limited and the purchaser.

Shriro Australia Pty Ltd
ABN 28 002 386 129
Telephone: 1800 648 556
Facsimile: 1800 628 577
Email: customercare@shriro.com.au

IM Ref: RUM90XCOM v4 11/10/2019